

**IMPORTANTE. LEA LAS INSTRUCCIONES DETENDIAMENTE Y  
CONSÉRVELAS PARA CONSULTAS POSTERIORES.**

- Es conveniente ajustar correctamente los elementos de fijación, y comprobar que no se desajustan.
- Debe sujetar la cama a la pared para evitar cualquier vuelco de la cama.
- Se recomienda que la litera no se utilice si alguno de sus componentes estructurales está roto o falta.
- **ATENCIÓN.** Los niños pueden sufrir estrangulamiento con elementos tales como cuerdas, cordones, cordeles, arneses y cinturones, unidos o colgados a la cama alta.
- **ADVERTENCIA.** Los niños pueden quedar atrapados entre la cama y la pared. Para evitar el riesgo de lesiones graves, la distancia entre la barrera de seguridad superior y la pared, no debe ser superior a 75 mm, o debe ser mayor de 230 mm. ( según la norma europea UNE EN 747-1:07)
- La cama superior de la litera no está recomendada para menores de 6 años
- El grueso máximo del colchón superior es de 210 mm.

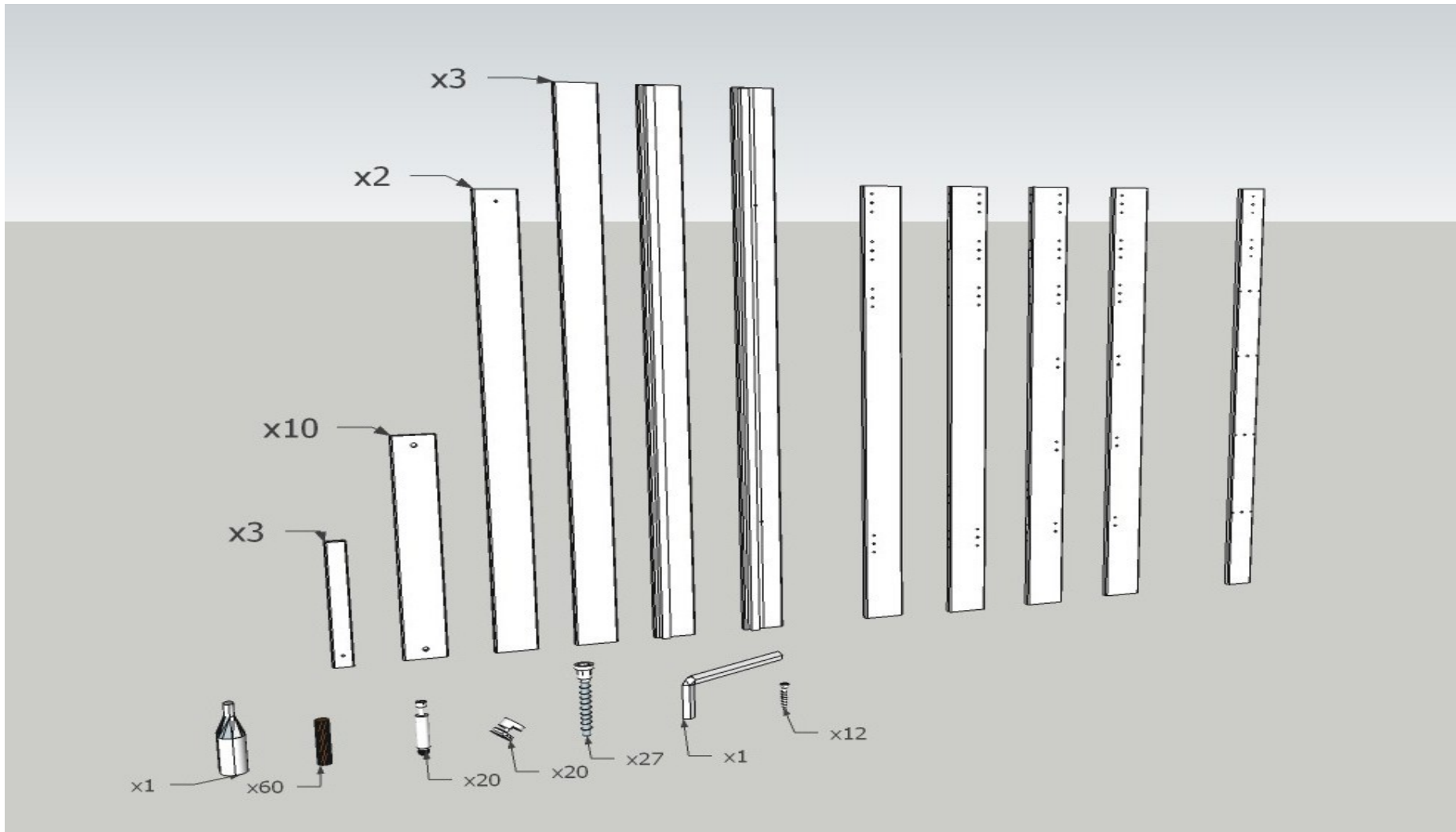

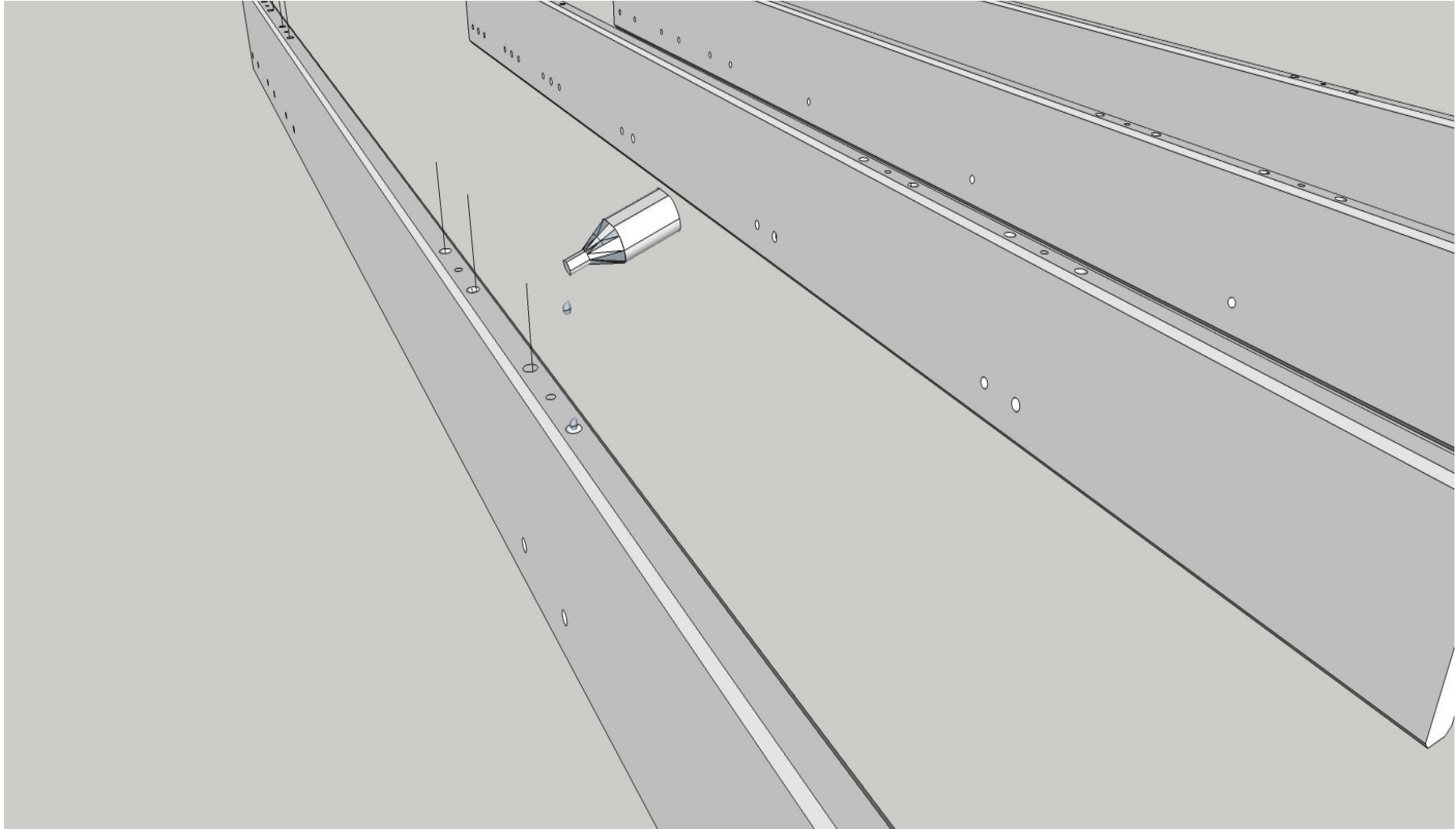

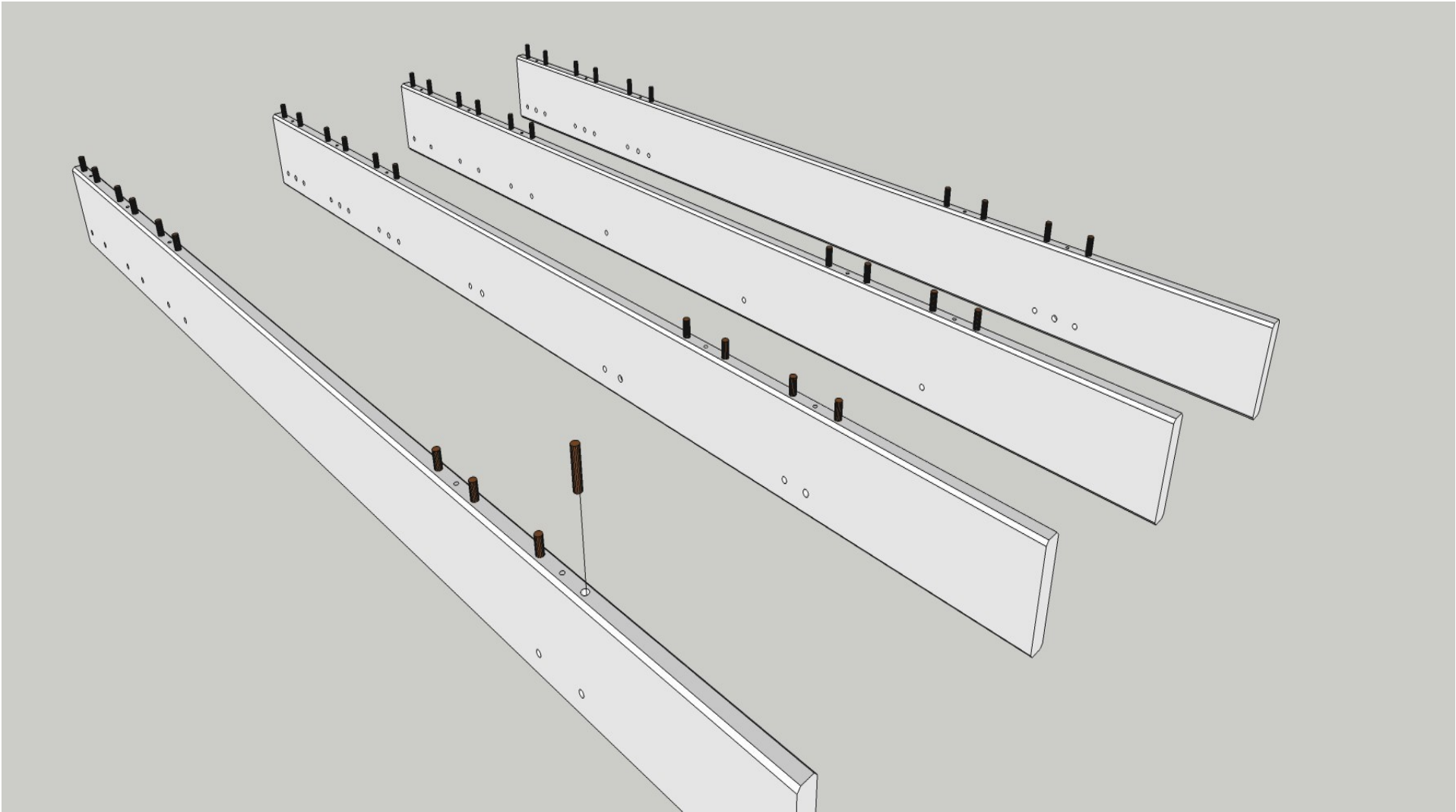

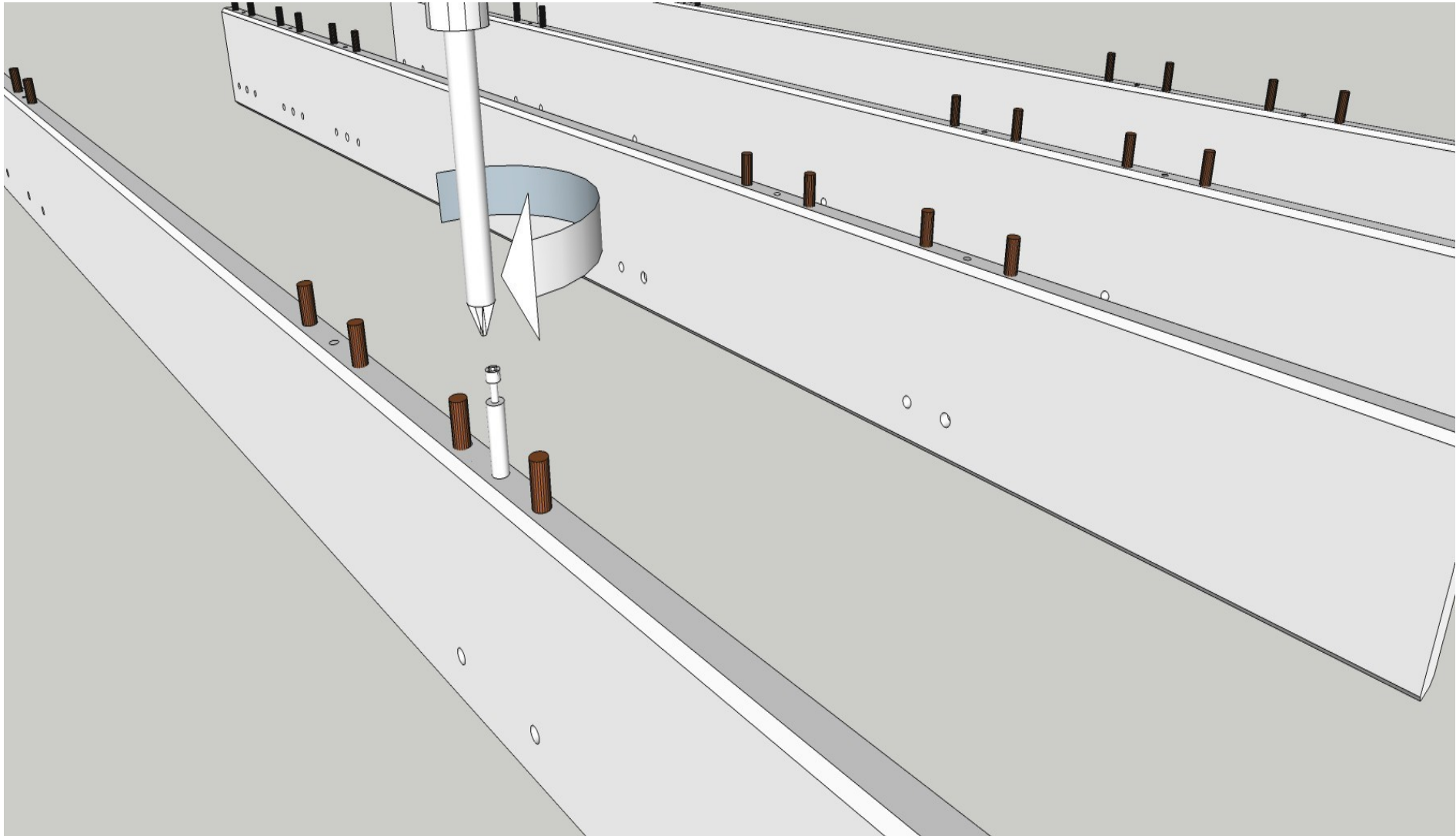

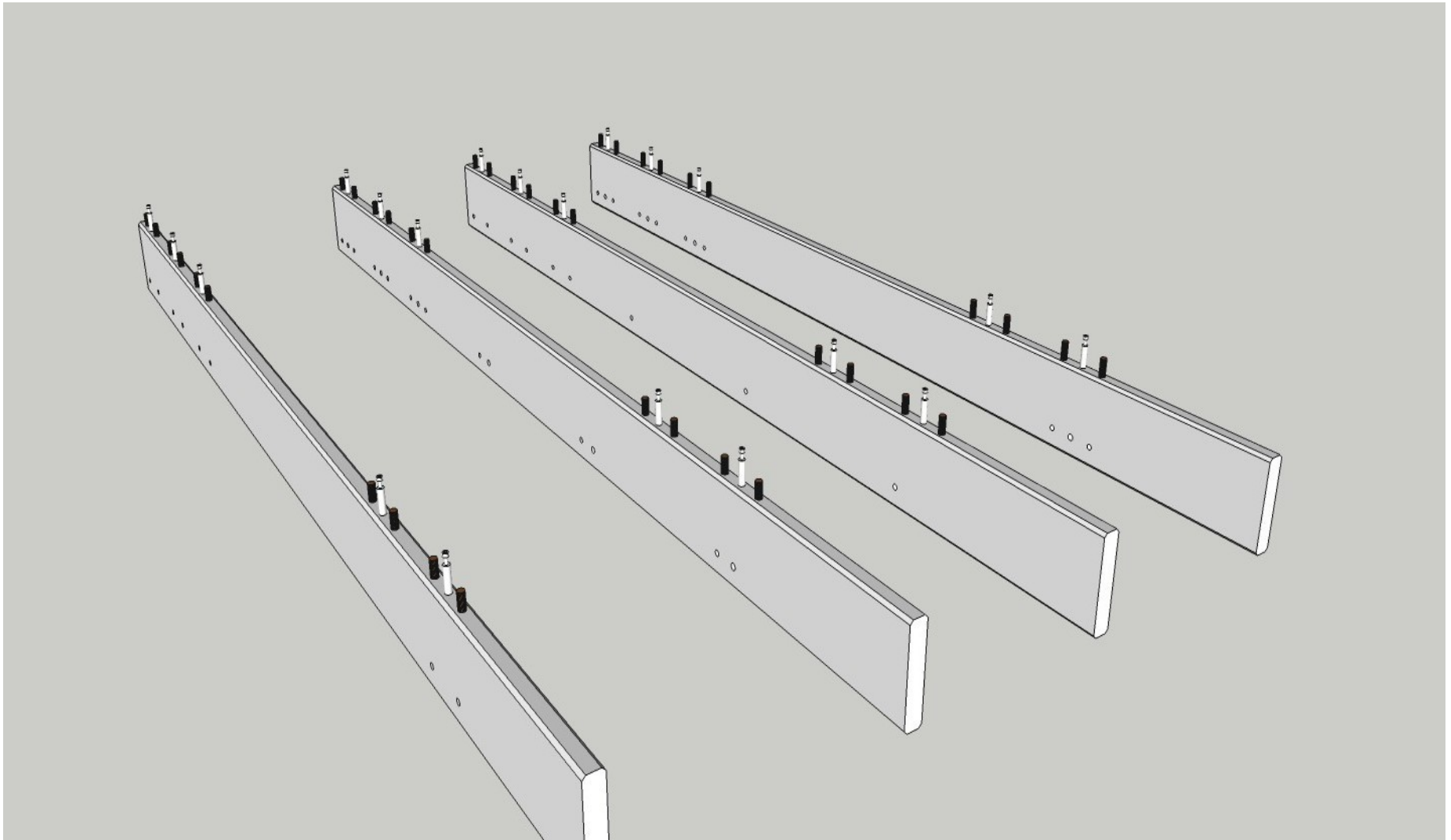

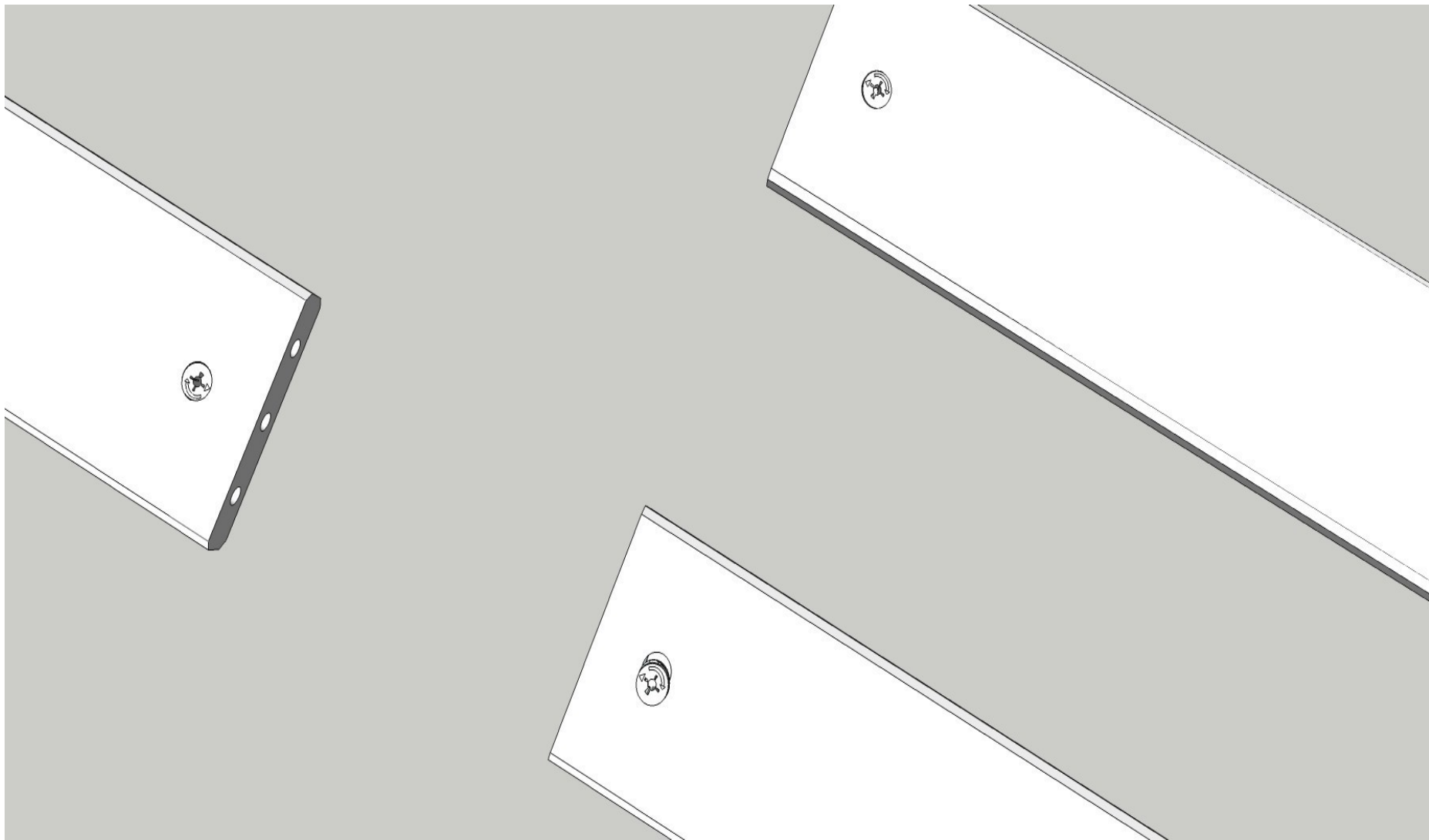

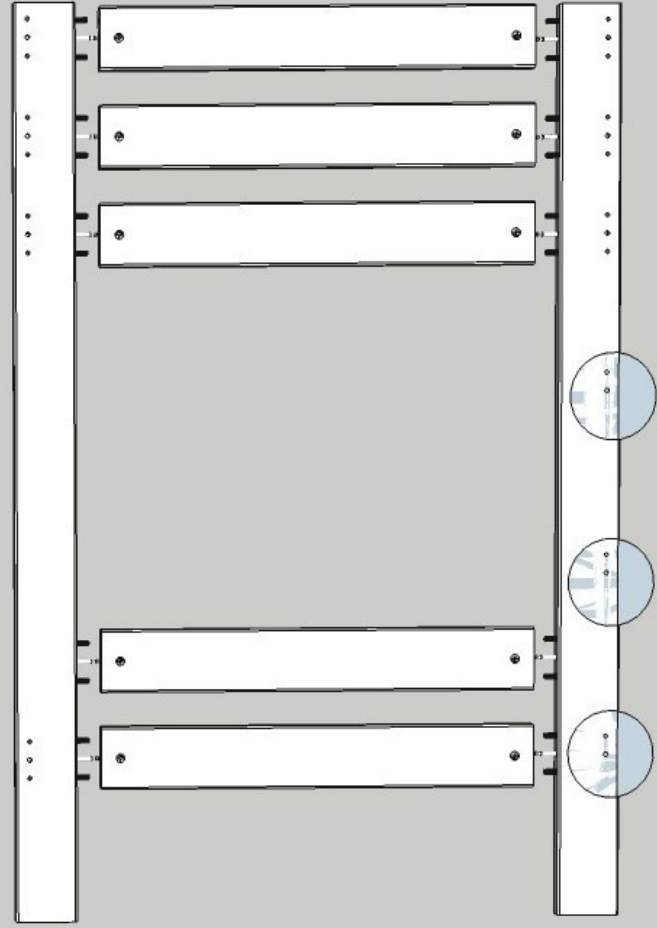
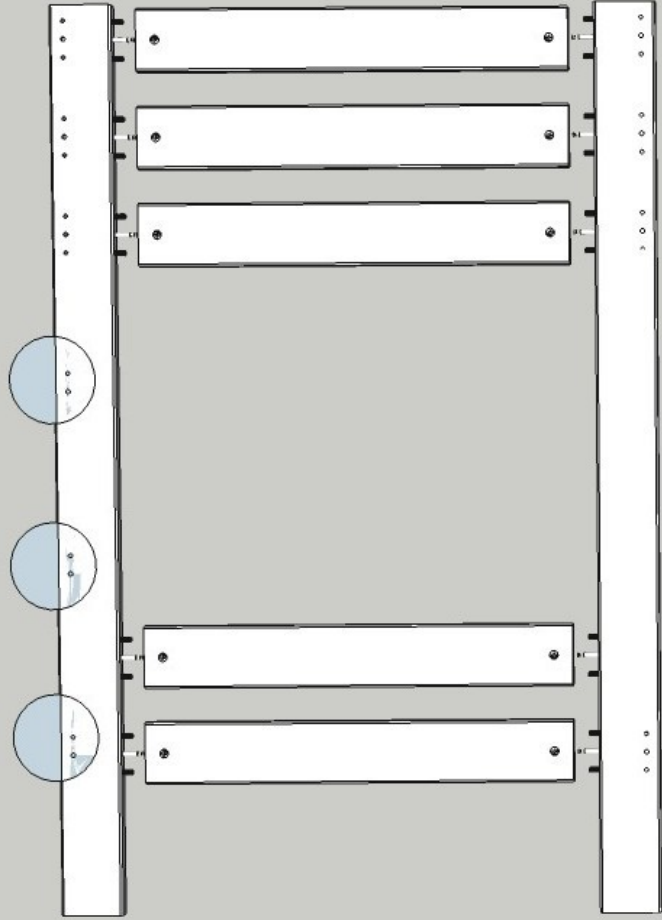



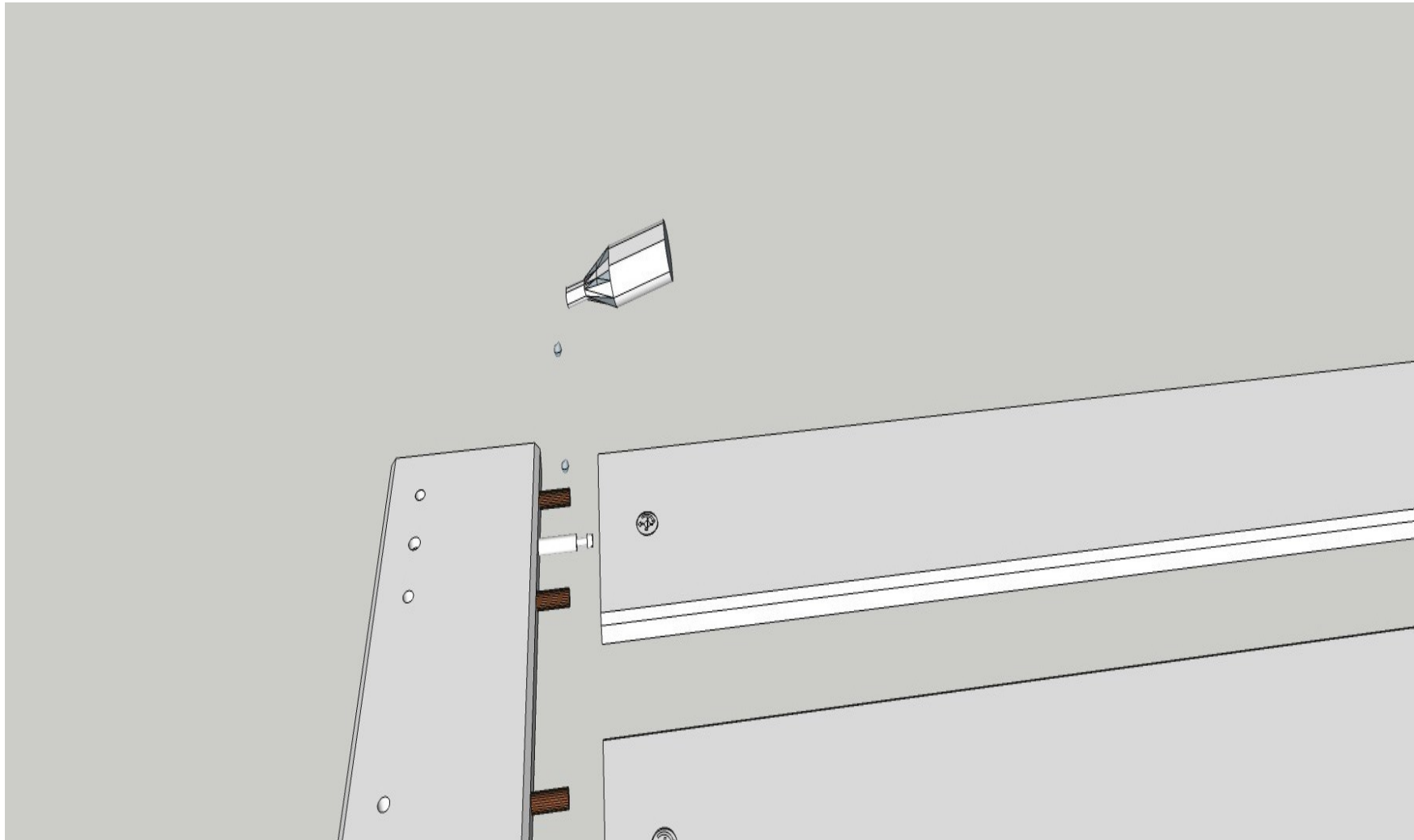

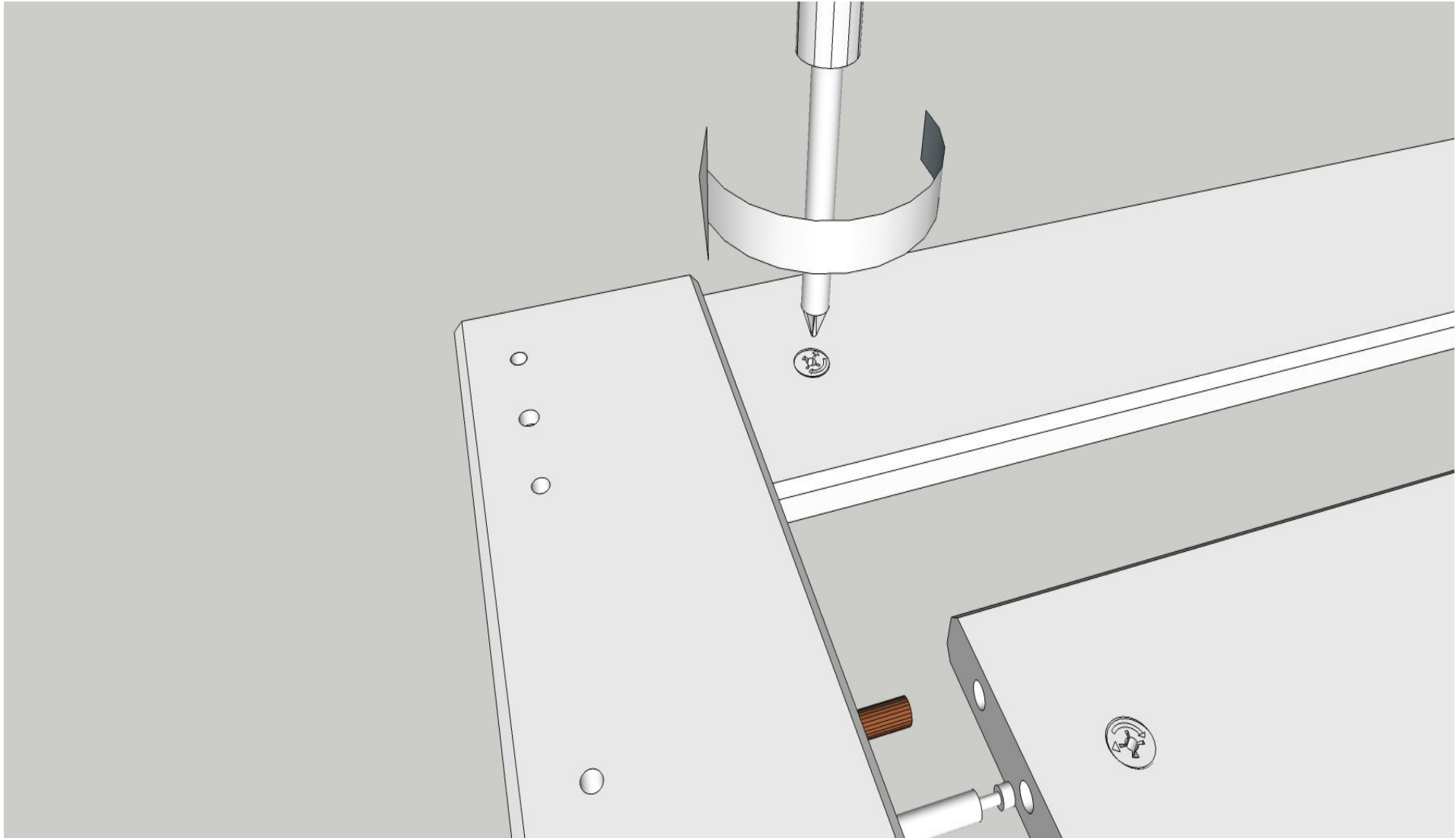



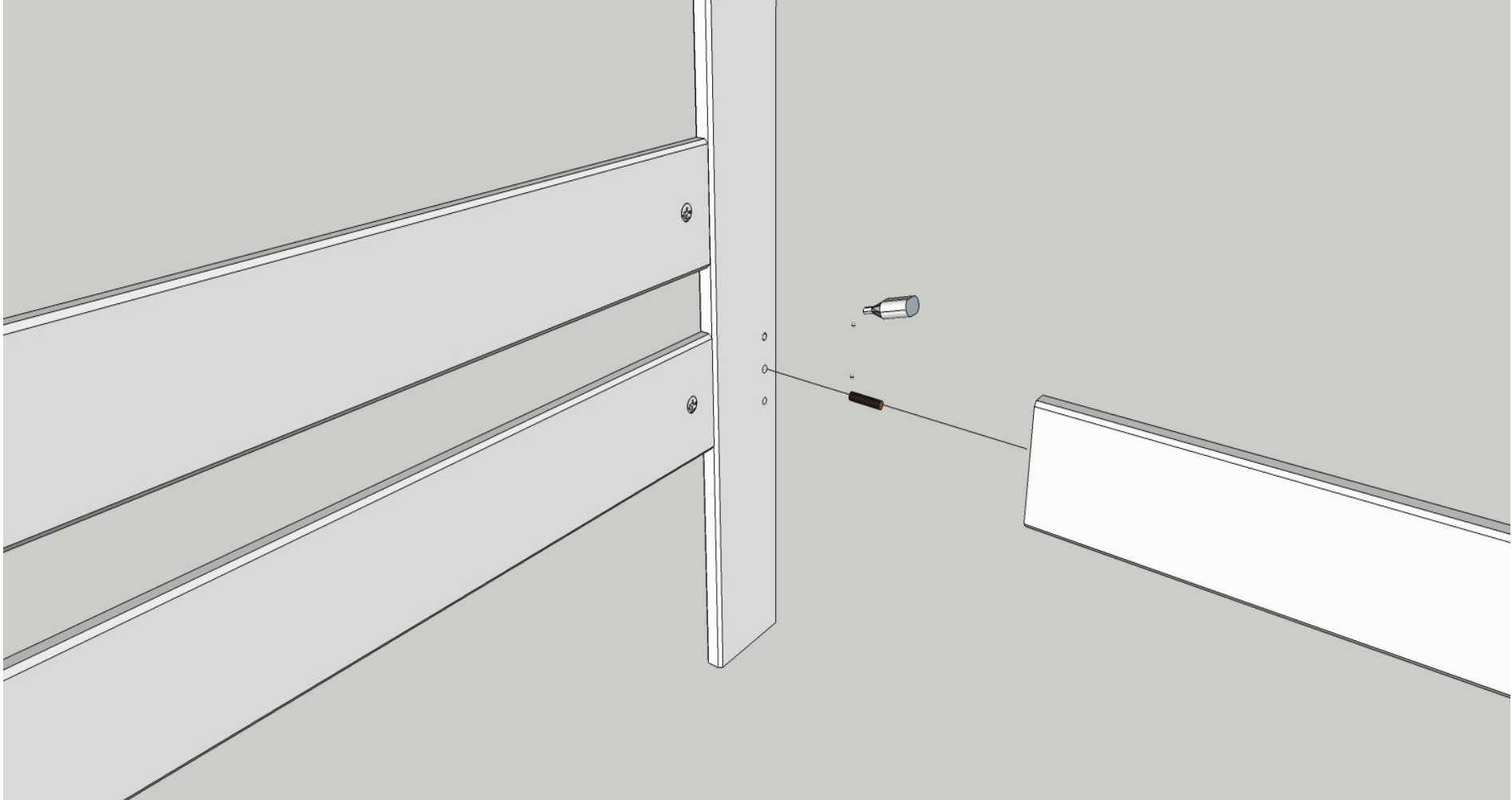

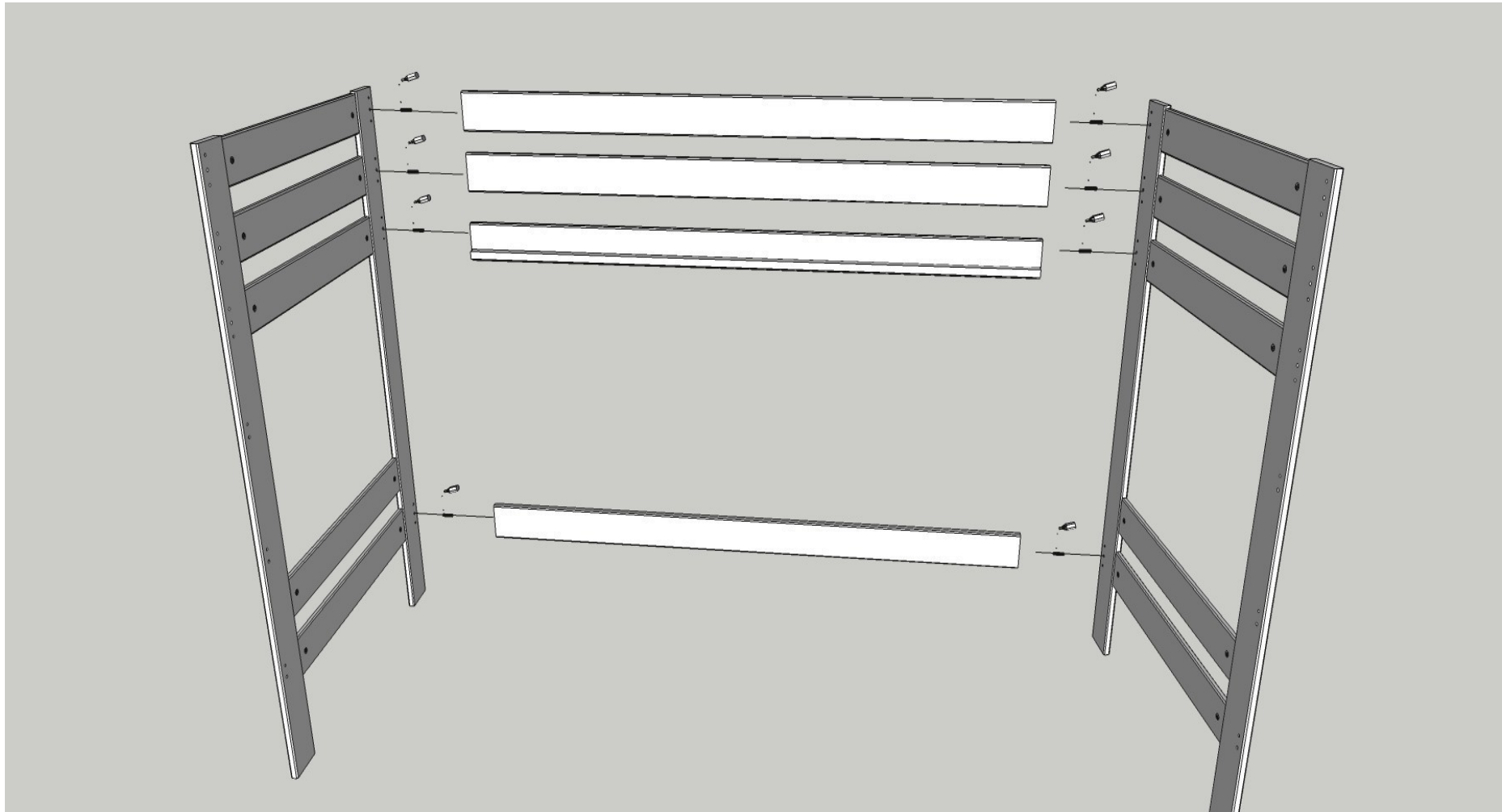

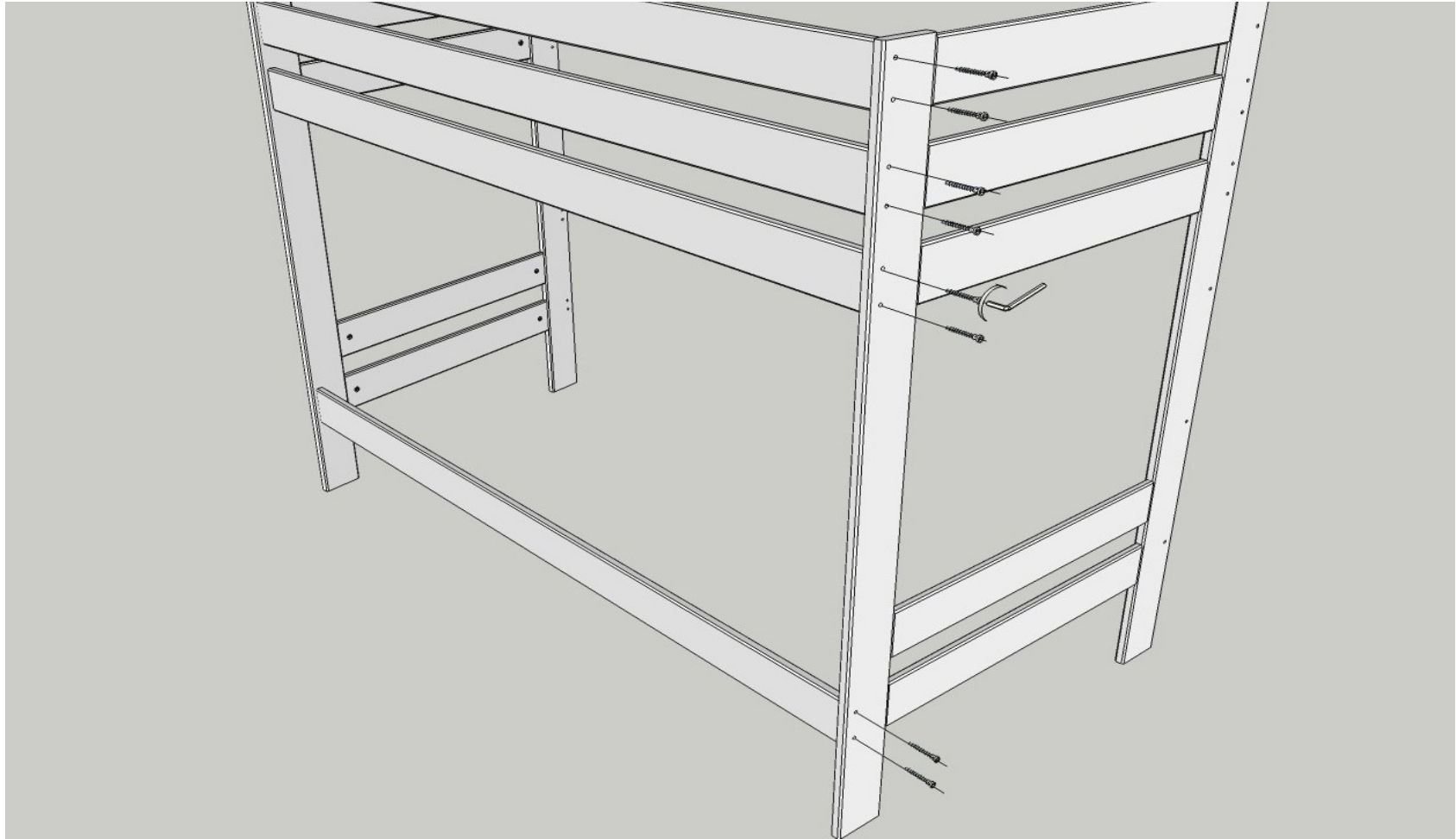

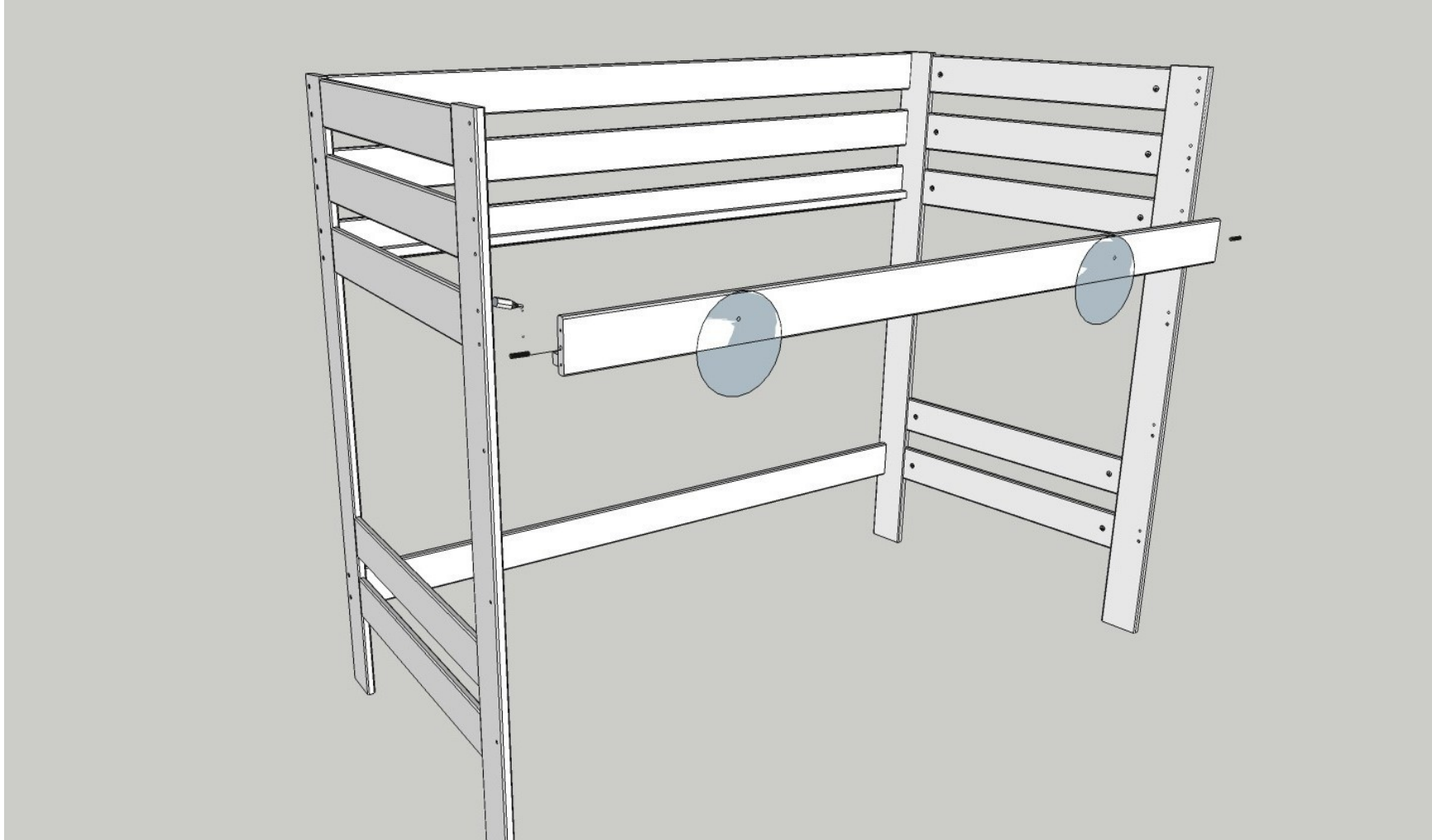

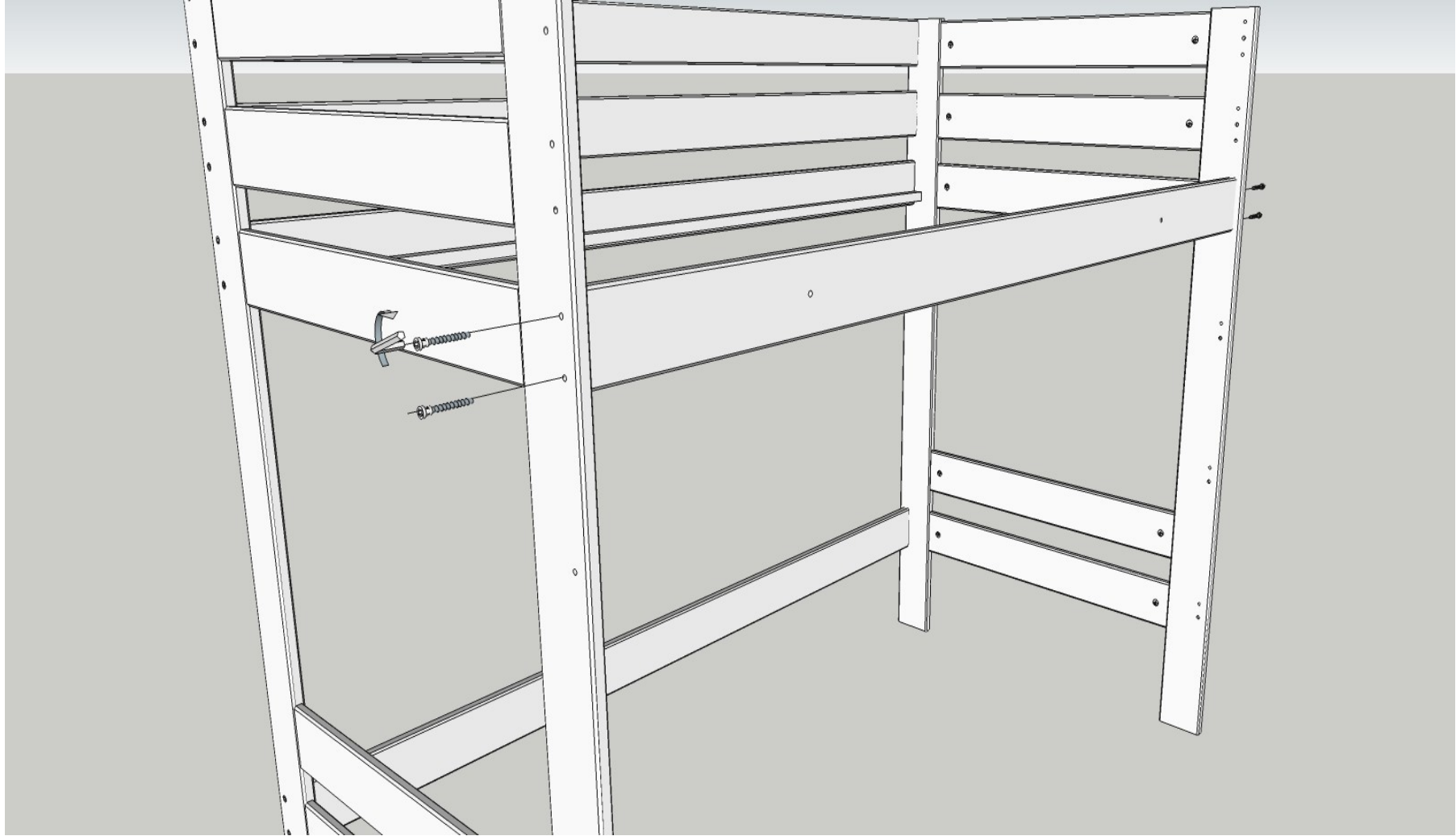



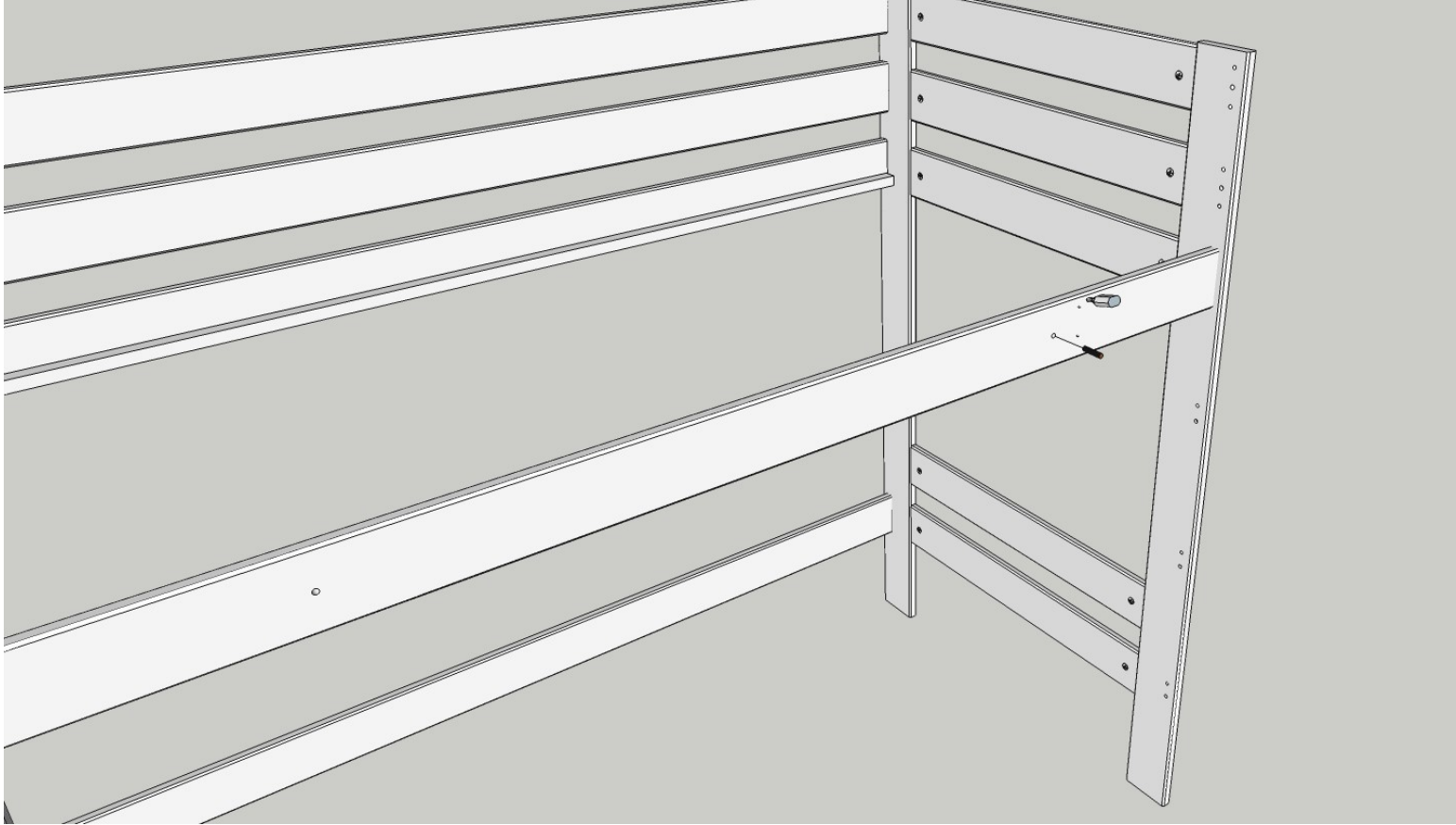

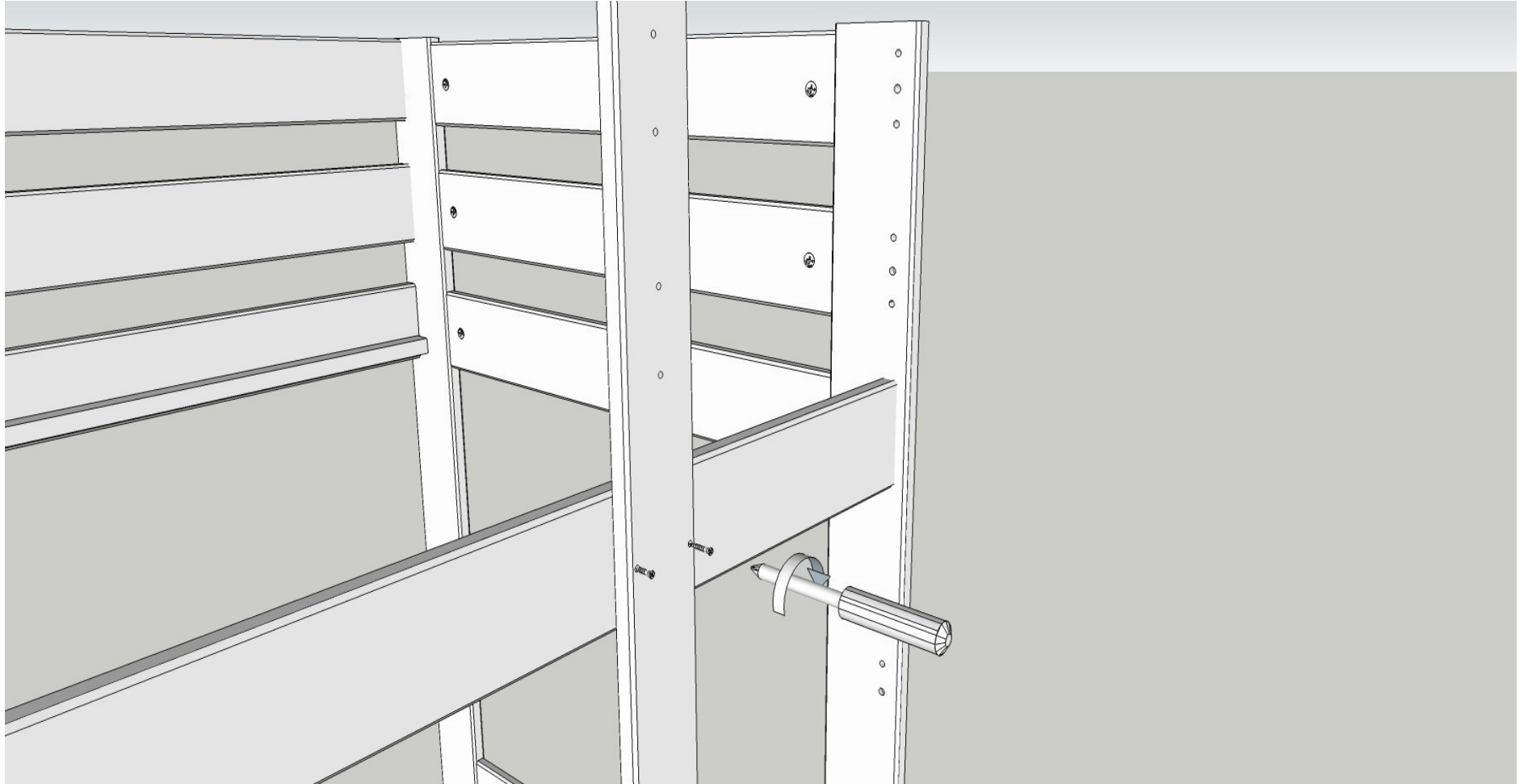

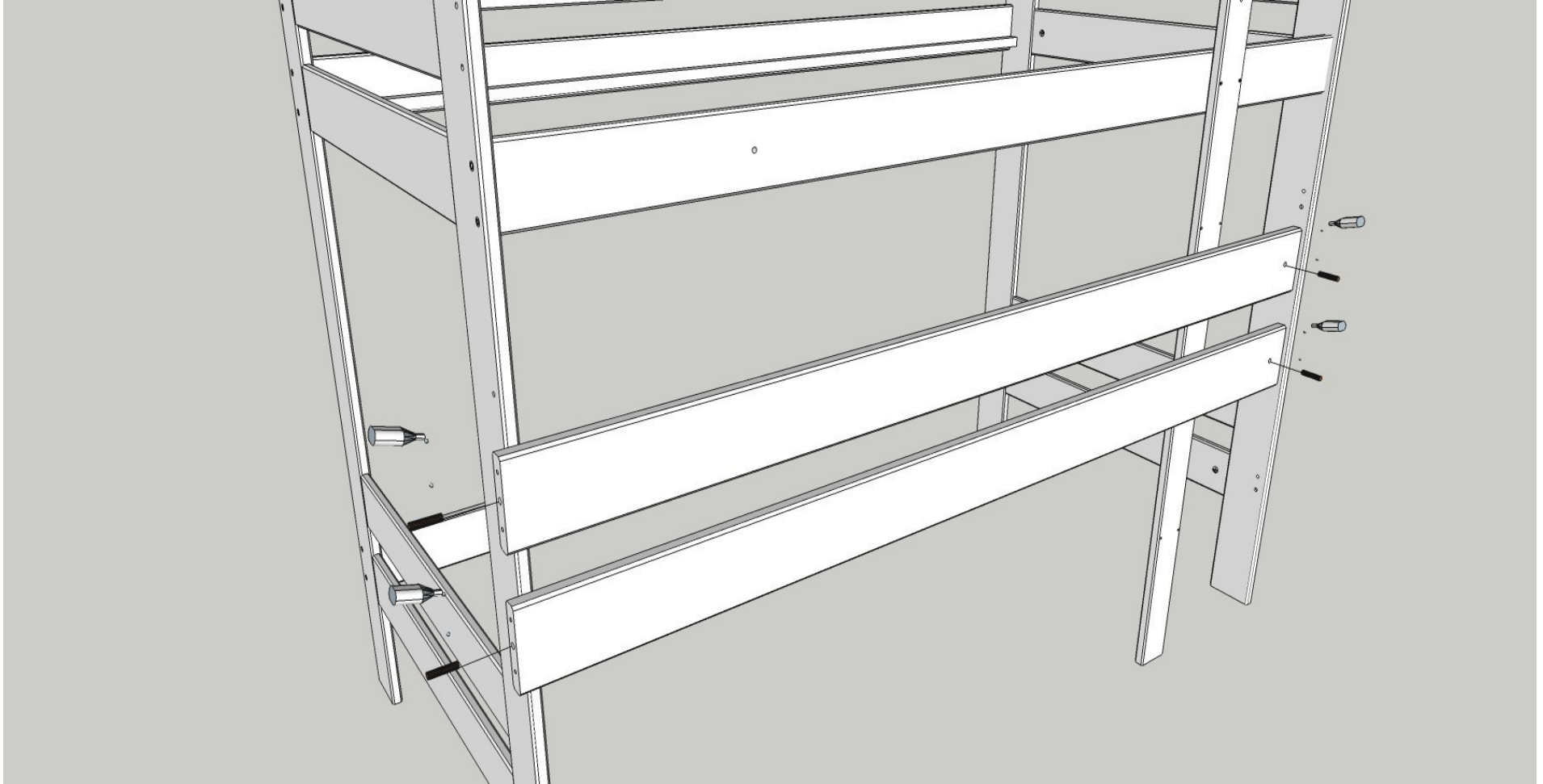

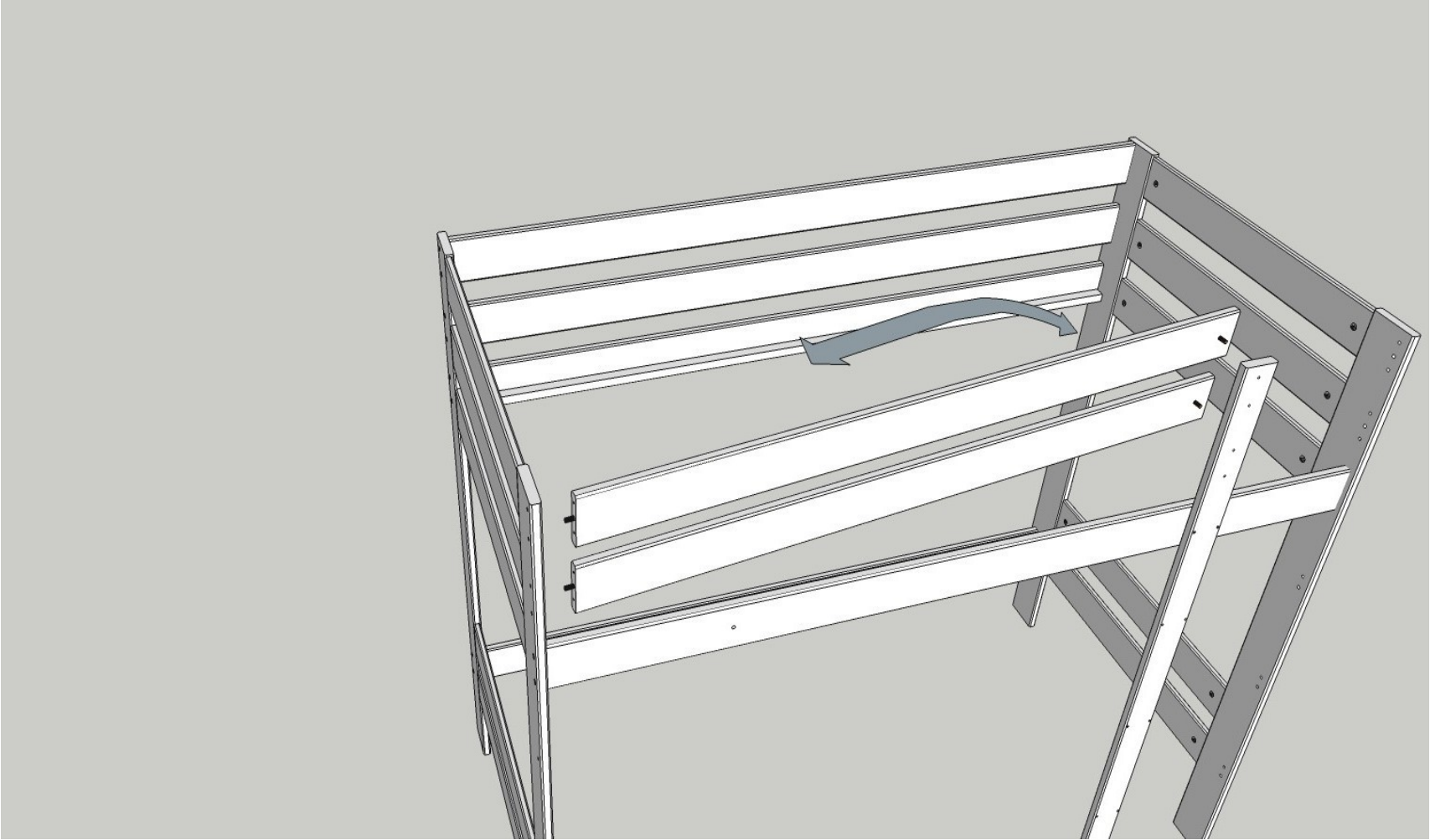

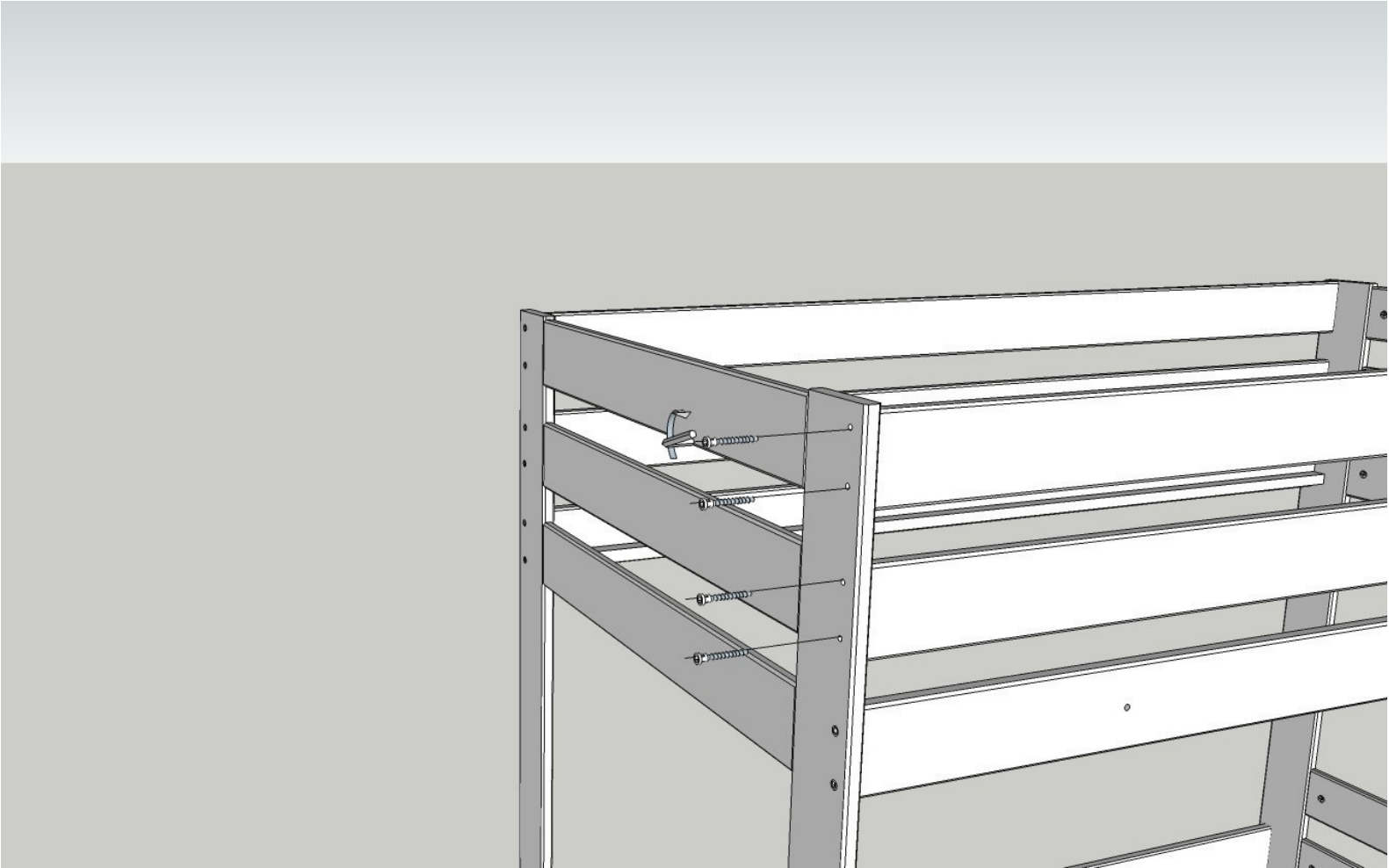

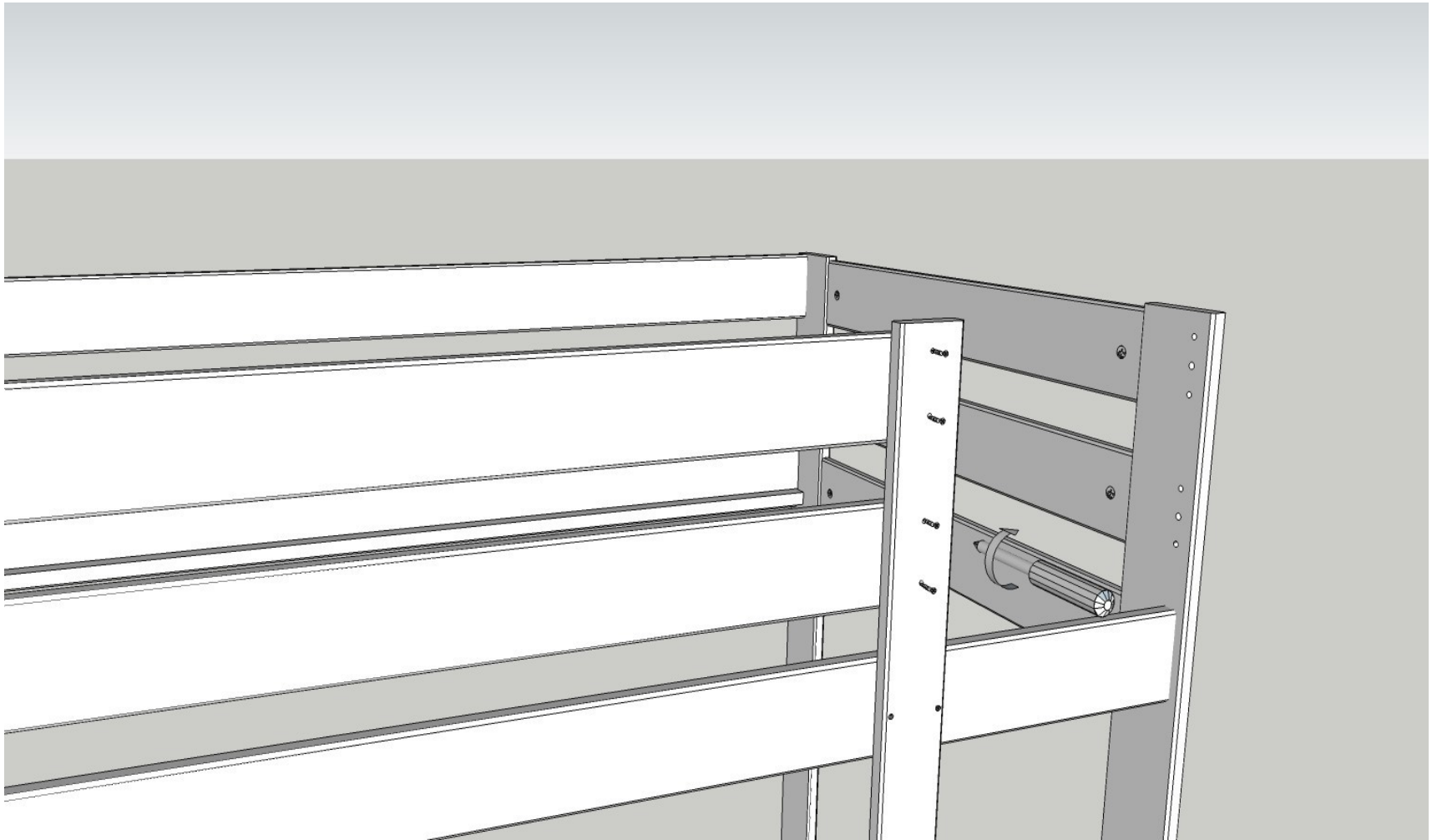

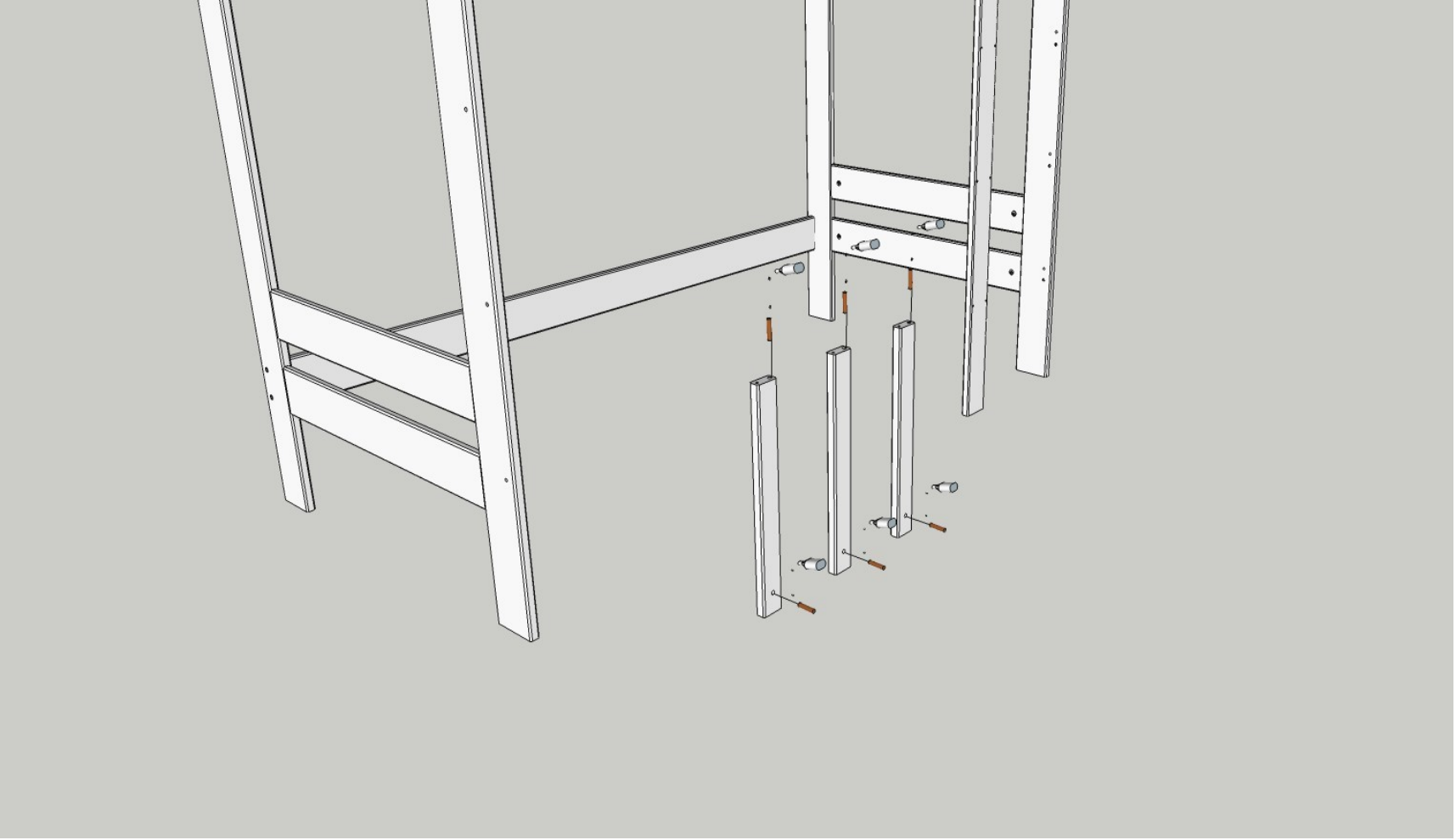





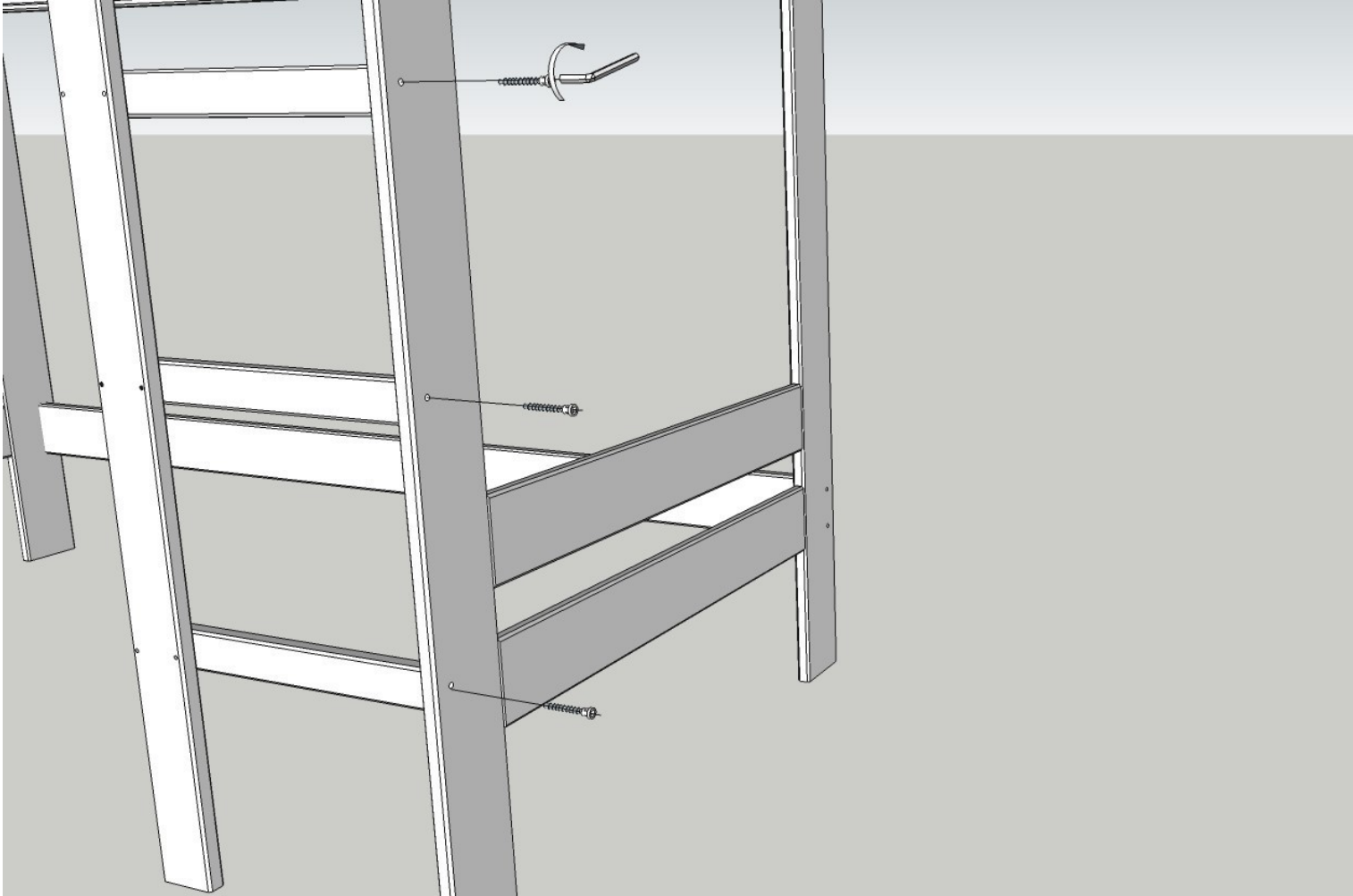

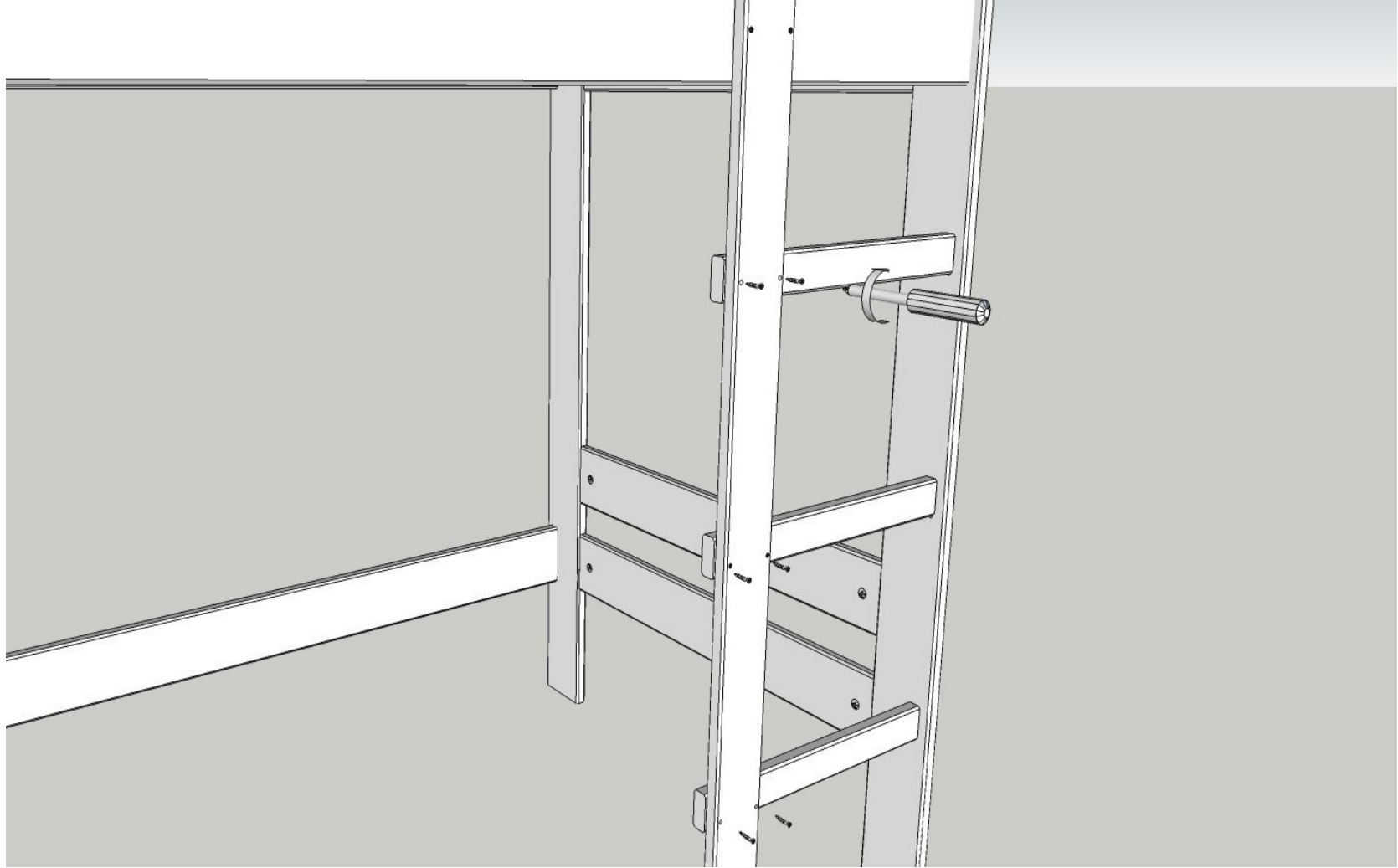

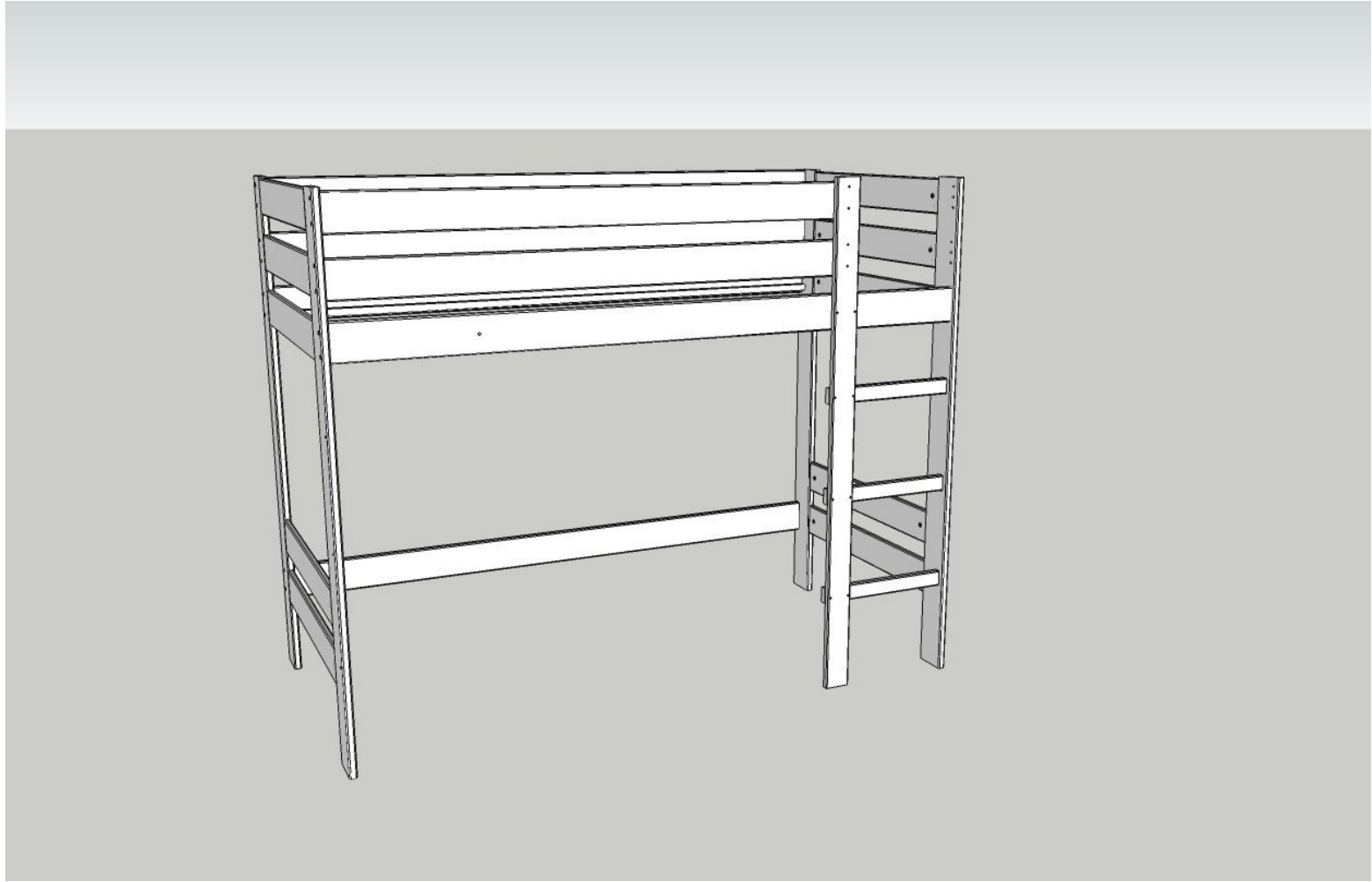

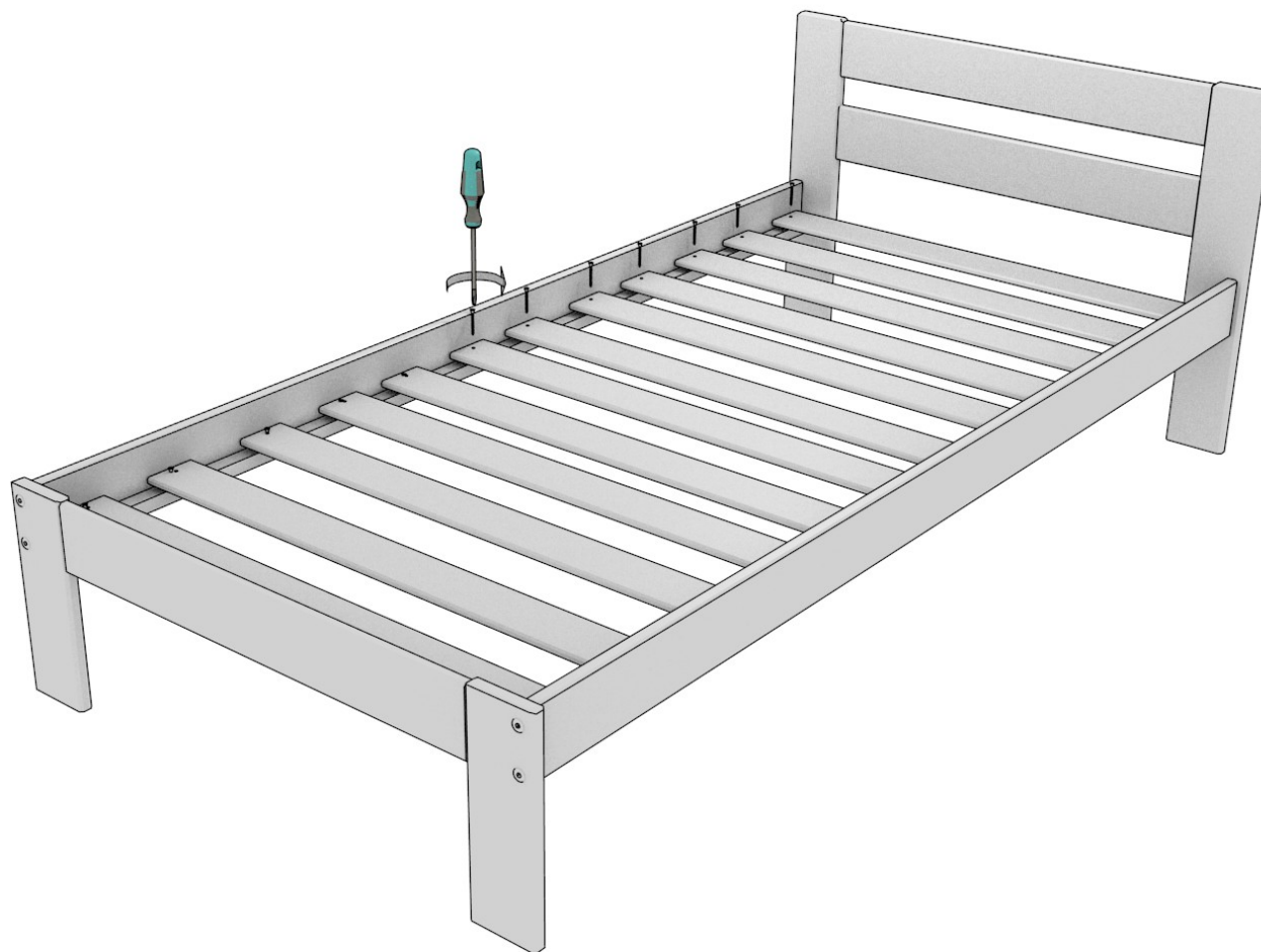

# MONTAJE LAMAS



 x 24